

Globe Valves

Type 01311 - Globe Valve



Cryogenic-Globe and Globe/Check Valves, PN50

- Bronze body and topwork
- "live loaded" gland packing
- "cleaned and degreased for oxygen service"

- Part No. 01311.X.0010 (H=270mm)**
- Part No. 01311.X.0020 (H=370mm)**
- Part No. 01311.X.5010 (H=270mm) Globe/Check Valve**
- Part No. 01311.X.5020 (H=370mm) Globe/Check Valve**
- Socket end for copper pipes acc. to DIN EN 12449 or ASTM B88

- Available options - on request only:
- Socket end for stainless steel stubs acc. to ISO 1127
 - Extension H up to 900mm
 - Valve with control disc (tapered design)



Applications:

Approved for air gases, vapours and cryogenic liquefied gases incl. LNG.
Working temperature: -196°C / -321°F (77K) up to +120°C / +248°F (393K)

Materials	DIN EN	ASTM
1 Body	CC491K	B 62 UNS C83600
2 Valve seal	PTFE / Carbon filled (25%)	
3 Disc	CW614N	B 283 UNS C38500
4 Bonnet gasket	PTFE	
5 Headpiece	CC493K	B 505 UNS C93200
6 Bolts	1.4301/A2 A 194 B8	
7 Elongation tube	1.4541 A 213 TP 321	
8 Stem	1.4301 A 276 Grade 304	
9 Gland packing	Graphite / PTFE	
10 Gland nut	CW614N	B 283 UNS C38500
11 Handwheel	Aluminium alloy	
12 Spring	CW452K	B 159 UNS C51900

Standard marking acc. to Pressure Equipment Directive 97/23/EC (PED).

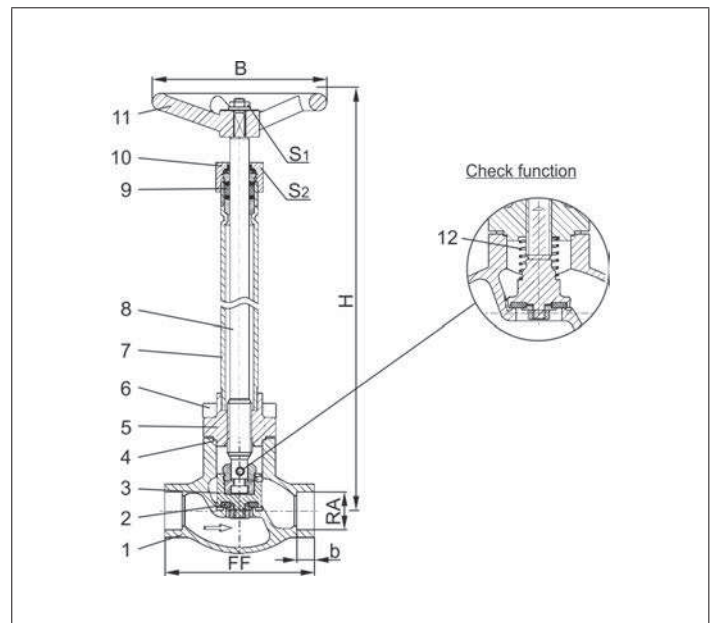

Type 01311 - Standard design	Technical data							
Nominal size	DN	10	15	20	25	32	40	50
Dimension code	.X.	X=DNRA. Example: valve DN15 for copper stub RA _ø 18mm. X=1518						
Face-to-face dimension	FF	60	85	85	115	115	140	160
Height	H	270mm or 370mm						
Outside pipe-Ø	RA	dependent on order						
Socket depth	b	6	6	8	8	10	13	20
Handwheel-Ø	B	100	100	100	100	125	125	125
Wrench size across flats	S ₁	10	10	10	10	13	13	13
Wrench size across flats	S ₂	30	30	30	30	36	36	36
Weight	ca. kg	1.4	1.7	2.1	2.4	3.3	4.7	7.2
Kvs-Value	m ³ /h	1.6	4.3	6.7	11.5	12.1	22.6	37.1
Cv-Value	gal/min	1.9	5.0	7.8	13.4	14.1	26.3	43.2

Dimensions in mm.